

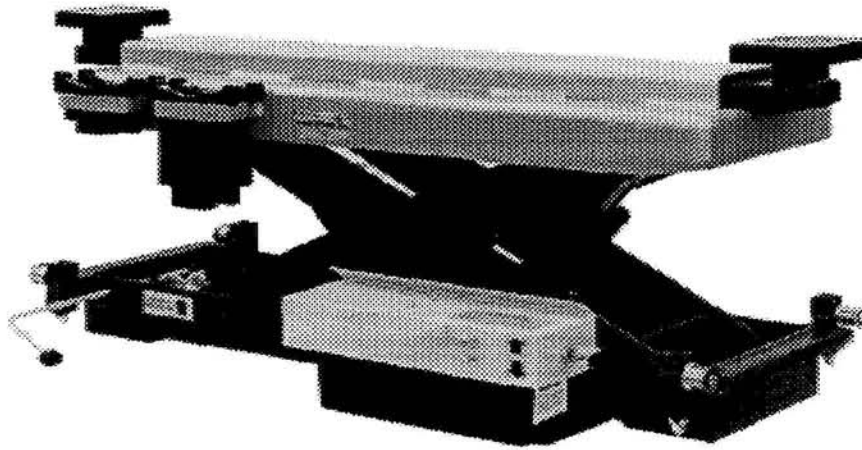

PARTS MANUAL



AIR / HYDRAULIC ROLLING JACK BEAM

Model # EELR109A
(6000 lbs. capacity)

**READ and SAVE THIS
PARTS MANUAL**

SUN is a trademark of
Snap-on Tools Corporation

December 1997

JACKING BEAM ASSEMBLY 6000 lbs.

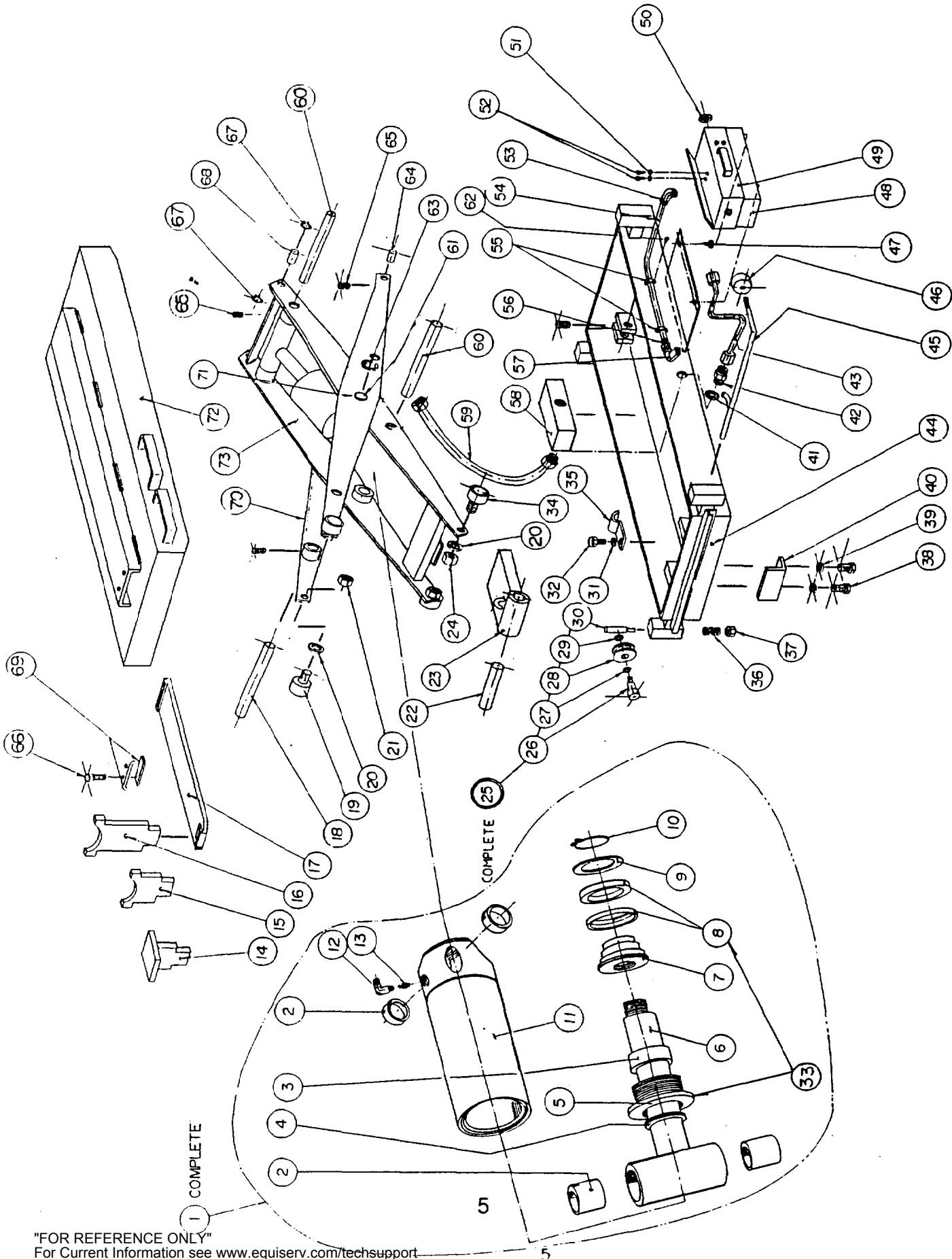

"FOR REFERENCE ONLY"
For Current Information see www.equiserv.com/techsupport

ITEM NO.	PART NO.	QUANTITY	DESCRIPTION
1	3-0362	2	HYDRAULIC CYLINDER ASSEMBLY
2	6-0800	8	SLEEVE BEARING
3	6-0799	2	SLEEVE BEARING
4*	6-0798	2	WIPER RING
5*	1-0880	2	GLAND
6	2-0616	2	PISTON ROD WELDMENT
7	1-0881	2	PISTON
8*	6-0579	2	SEAL AND WIPER RING
9	1-0725	2	KEEPER WASHER
10	6-0581	2	EXTERNAL SNAP RING
11	2-0614	2	CYLINDER TUBE WELDMENT
12	1-0600	2	ELBOW, 90 DEGREES
13	6-0911	2	VELOCITY FUSE
14	2-0264	2	NEOPRENE RISER
15	2-0163	2	RISER SHORT
16	2-0164	2	RISER TALL
17	1-0569	2	LIFTING ARM
18	1-0584	1	SCISSOR PIN "B"
19	6-0076	2	UPPER CAM FOLLOWER
20	1-0228	2	SPACER
21	6-0672	2	HEX NUT, 5/8" - 18UNF
22	1-0561	1	SAFETY PIN
23	1-0562	1	SAFETY STOP
24	6-0040	2	JAM NUT, 5/8" - 18UNF
25	2-0259	4	ROLLER ASSEMBLY
26	6-0206	4	SHOULDER BOLT, 3/8" X 1" LG.
27	6-0223	4	THRUST WASHER, 3/8"
28	2-0098	4	TRACK ROLLER ASSEMBLY
29	6-0224	4	THRUST WASHER, 3/8"
30	1-0204	4	SPRING STEM
31	6-0056	7	LOCKWASHER, 1/4"
32	6-0178	7	HEX BOLT, 1/4" - 20UNC X 3/4" LG.
33*	0-0190	1	HYDRAULIC CYLINDER SEAL KIT
34	1-0130	2	CAM FOLLOWER
35	6-0671	3	CLIP
36	6-0081	4	SPRING

ITEM NO.	PART NO.	QUANTITY	DESCRIPTION
37	6-0042	4	NYLOCK NUT, 3/8" UNC
38	6-0030	4	HEX BOLT, 3/8" - 16UNC x 3/4" LG.
39	6-0058	4	LOCKWASHER, 3/8"
40	1-0608	2	KEEPER BRACKET
41	6-0670	1	SNAP-IN GROMMET
42	6-0281	1	ADAPTER, 1/4" NPT, M - 1/4" JIC, M
43	1-0803	1	HYDRAULIC LINE
44	4-0154	1	BOTTOM FRAME WELDMENT
45	1-0589	1	LEVER WELDMENT
46	6-0251	1	KNOB, 3/8" - 16UNC
47	6-0178	2	HEX BOLT, 1/4" x 3/4" LG.
48	6-0960	1	AIR/HYDRAULIC PUMP
49	2-0757	1	PUMP SHIELD
50	6-0968	1	JAM NUT, 1/4" NPT
51	6-0207	2	FLAT WASHER, #10
52	6-0068	2	ROUND HD. SCREW #10 x 1/2" LG
53	6-0966	1	ELBOW, 90 DEG., 1/4" NPT, F- 3/8" POLY
54	1-1010	1	POLY TUBE
55	6-0536	2	TUBE CLAMP
56	6-0710	1	ADAPTER
57	6-0967	1	ELBOW 90 DEG., 1/4" NPT, F - 1/4" NPT,F
58	1-0560	1	MANIFOLD
59	1-0601	2	HYDRAULIC HOSE ASS'Y
60	1-0583	2	SCISSOR PIN "A"
61	1-0574	1	CENTER SHAFT
62	6-0169	2	SELF TAPPING SCRW, #10 x 3/8" LG.
63	6-0329	2	RETAINING RING
64	1-0599	2	BOTTOM HINGE PIN
65	6-0438	10	SET SCREW, 1/4" - 20UNC x 1/2" LG.
66	6-0441	4	BUTTON HD. CAP SCRW, 1/4" - 20UNF x 3/8" LG.
67	6-0072	4	RETAINING RING
68	1-0598	2	TOP HINGE PIN
69	1-0262	2	ARM STOP
70	3-0288	2	SCISSOR ARM WELDMENT, OUTSIDE
71	6-0328	2	THRUST WASHER
72	3-0286	1	TOP COVER WELDMENT
73	3-0289	1	SCISSOR ARM WELDMENT, INSIDE

NOTE: ITEMS LISTED WITH * ARE INCLUDED IN ITEM 33 SEAL KIT.

AIR HYDRAULIC PUMP

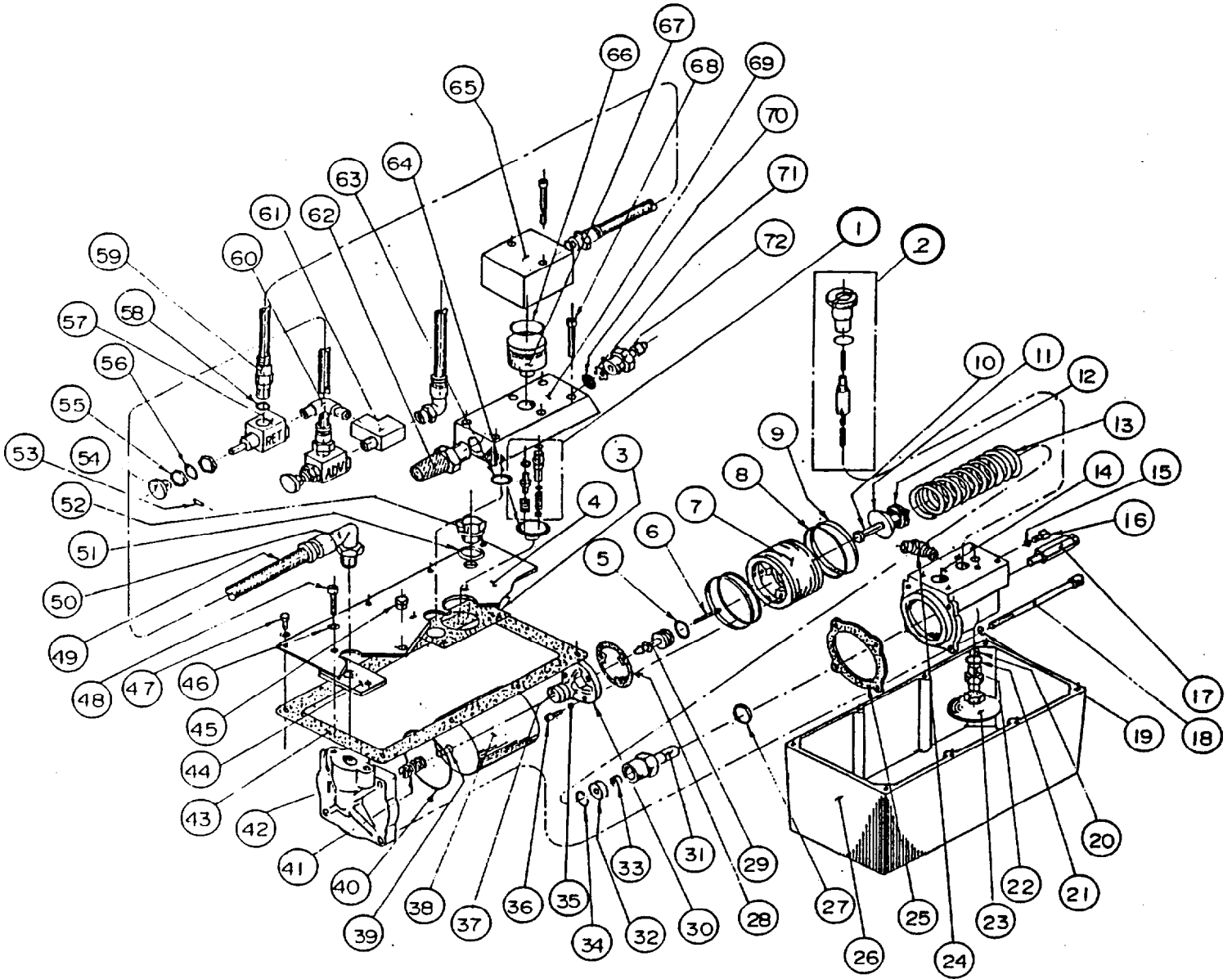

AIR /HYDRAULIC PUMP

ITEM NO.	PART NO.	QUANTITY	DESCRIPTION
1	6-0999	1	CHECK AND RELEASE VALVES ASS
2	6-1000	2	RELEASE VALVE ASSEMBLY
3	6-1001	1	GASKET
4	6-1002	1	COVER PLATE
5	6-1003	1	"O" RING
6	6-1004	1	SPRING
7	6-1005	1	PISTON BODY
8	6-1006	2	"O" RING
9	6-1007	2	PISTON RING
10	6-1008	1	PISTON
11	6-1009	1	SPRING GUIDE
12	6-1010	1	BUMPER
13	6-1011	1	COMPRESSION SPRING
14	6-1012	1	PUMP BODY
15	6-1013	1	COPPER WASHER
16	6-1014	1	CAP SCREW
17	6-1015	1	RELIEF VALVE ASSEMBLY
18	6-1016	4	HEX-SOCKET CAP SCREW
19	6-1017	4	LOCK WASHER
20	6-1018	1	STEEL BALL
21	6-1019	1	COPPER WASHER
22	6-1020	1	FILTER ADAPTER
23	6-1021	1	FILTER ASSEMBLY
24	6-1022	1	ELBOW, 90°
25	6-1023	1	GASKET
26	6-1024	1	RESERVOIR
27	6-1025	1	COPPER WASHER
28	6-1026	1	GASKET
29	6-1027	1	EXHAUST VALVE STEM
30	6-1028	1	PISTON
31	6-1029	1	CYLINDER
32	6-1030	1	RETAINER
33	6-1031	1	"U" CUP
34	6-1032	1	RETAINING RING
35	6-1033	3	LOCK WASHER
36	6-1034	3	HEX-SOCKET CAP SCREW
37	6-1035	1	PISTON POPPET

AIR /HYDRAULIC PUMP

ITEM NO.	PART NO.	QUANTITY	DESCRIPTION
38	6-1036	1	AIR CYLINDER
39	6-1037	1	CAP SCREW
40	6-1038	1	BACKUP RING
41	6-1039	1	SPRING
42	6-1040	1	REAR HEAD
43	6-1041	1	GASKET
44	6-1042	1	GASKET
45	6-1043	1	PLUG
46	6-1044	2	FLAT WASHER
47	6-1045	8	SCREW
48	6-1046	2	HEX-SOCKET CAP SCREW
49	6-1047	2	POLYTUBE L= 10" LG.
50	6-1048	2	ELBOW FITTING
51	6-1049	1	RUBBER GASKET
52	6-1050	1	BREATHER CAP
53	6-1051	2	HEX-SOCKET SET SCREW
54	6-1052	2	BUTTON
55	6-1053	4	LOCKNUT
56	6-1054	2	TOOTH LOCK WASHER
57	6-1055	2	AIR VALVE
58	6-1056	2	PLASTIC WASHER
59	6-1057	2	STRAIGHT FITTING
60	6-1058	1	ELBOW 90°
61	6-1059	1	CONNECTOR
62	6-1060	1	FILTER
63	6-1061	2	"O" RING
64	6-1062	1	"O" RING
65	6-1063	1	VALVE BODY
66	6-1064	1	"O" RING
67	6-1065	1	PISTON
68	6-1066	6	HEX-SOCKET CAP SCREW
69	6-1067	1	VALVE BODY
70	6-1068	1	FILTER
71	6-1069	1	TOOTH LOCKWASHER
72	6-1070	1	STRAIGHT ADAPTER